



## LOW-VOLTAGE DIFFERENTIAL SCSI (LVD) 27-LINE REGULATOR SET

### FEATURES

- SCSI SPI-2, SPI-3 and SPI-4 LVD SCSI 27-Line, Low-Voltage Differential Regulator
- 2.7-V to 5.25-V Operation
- Integrated Regulator Set for LVD SCSI
- Differential Failsafe Bias

### APPLICATIONS

- Servers
- Workstations
- RAID Boxes

### DESCRIPTION

The UCC561 low-voltage differential (LVD) regulator set is designed to provide the correct reference voltages and bias currents for LVD termination resistor networks (475 Ω, 121 Ω, and 475 Ω). The device also provides a 1.3-V output for “diff sense” signaling. With the proper resistor network, the UCC561 solution meets the common mode bias impedance, differential bias, and termination impedance requirements of SPI-2 (Ultra2), SPI-3 (Ultra3/Ultra160) and SPI-4 (Ultra320). The UCC561 is not intended for SPI-5 applications.

This device incorporates into a single monolith, two sink/source reference voltage regulators, a 1.3-V buffered output and protection features. The protection features include thermal shutdown and active current-limiting circuitry. The UCC561 is offered in 16-pin SOIC (DP) package.

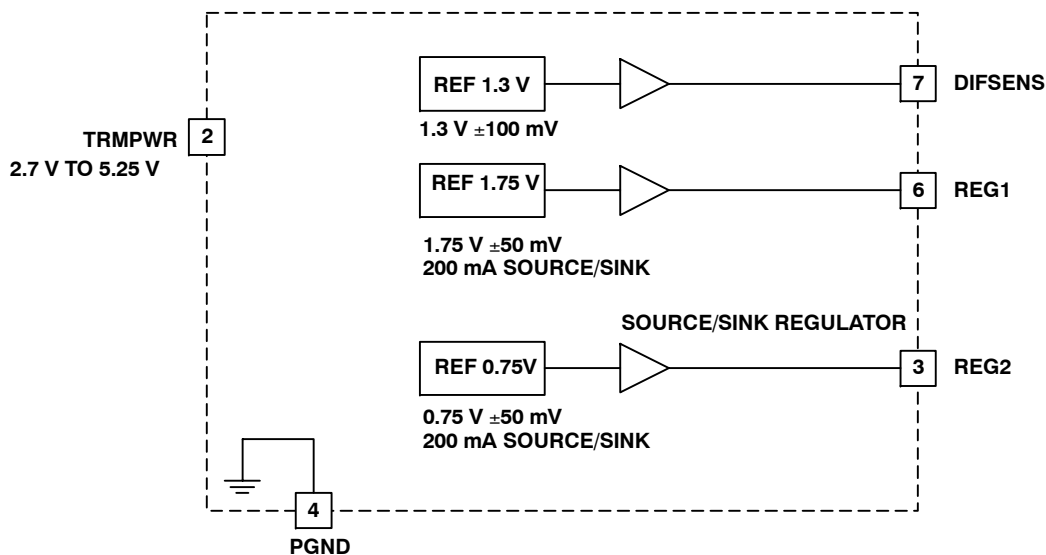

UDG-98093



Please be aware that an important notice concerning availability, standard warranty, and use in critical applications of Texas Instruments semiconductor products and disclaimers thereto appears at the end of this data sheet.



This integrated circuit can be damaged by ESD. Texas Instruments recommends that all integrated circuits be handled with appropriate precautions. Failure to observe proper handling and installation procedures can cause damage.

ESD damage can range from subtle performance degradation to complete device failure. Precision integrated circuits may be more susceptible to damage because very small parametric changes could cause the device not to meet its published specifications.

**ORDERING INFORMATION**

| PRODUCT | PACKAGE-LEAD | PACKAGE DESIGNATOR | SPECIFIED TEMPERATURE RANGE | ORDERING NUMBER | TRANSPORT MEDIA, QUANTITY |
|---------|--------------|--------------------|-----------------------------|-----------------|---------------------------|
| UCC561  | SOIC-16      | DP                 | 0°C to 70°C                 | UCC561DP        | Rail, 70                  |

(1) For the most current specification and package information, refer to our web site at [www.ti.com](http://www.ti.com).

**ABSOLUTE MAXIMUM RATINGS**

over operating free-air temperature range unless otherwise noted<sup>(1)(2)</sup>

|                                       | UCC561     | UNIT |
|---------------------------------------|------------|------|
| TERMPWR                               | 6          | V    |
| Package dissipation                   | 1.2        | W    |
| Junction temperature, T <sub>J</sub>  | -55 to 150 | °C   |
| Storage temperature, T <sub>stg</sub> | -65 to 150 | °C   |

(1) Stresses beyond those listed under “absolute maximum ratings” may cause permanent damage to the device. These are stress ratings only, and functional operation of the device at these or any other conditions beyond those indicated under “recommended operating conditions” is not implied. Exposure to absolute-maximum-rated conditions for extended periods may affect device reliability.

(2) Currents are positive into and negative out of the specified terminals.

**RECOMMENDED OPERATING CONDITIONS**

|  | MIN  | NOM | MAX  | UNIT |
|--|------|-----|------|------|
| V <sub>TERMPWR</sub> , TermPower voltage | 2.70 |     | 5.25 | V    |

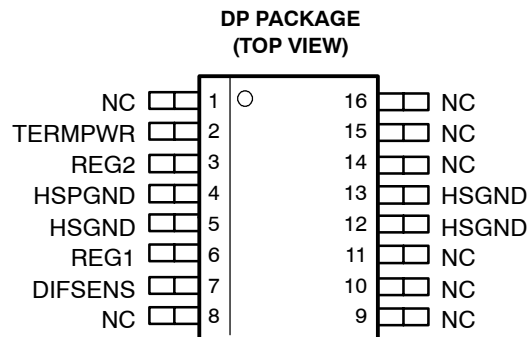

NC = No connection

**ELECTRICAL CHARACTERISTICS**
 $T_J = 0^\circ\text{C to } 70^\circ\text{C}$ ,  $V_{\text{TEMPWR}} = 3.3\text{ V}$  unless otherwise noted<sup>(1)</sup>

| PARAMETER  | TEST CONDITIONS   | MIN  | TYP  | MAX  | UNIT          |
|--|---|------|------|------|---------------|
| <b>TERMPWR Supply Current</b>                        |   |      |      |      |               |
| TERMPWR supply current                               | No load   |      |      | 40   | mA            |
| TERMPWR voltage                                      |   | 2.70 |      | 5.25 | V             |
| <b>Regulator</b>                                     |   |      |      |      |               |
| 1.75-V regulator                                     | REG1 ( $\pm 125\text{ mA}$ )                                | 1.70 | 1.75 | 1.80 | V             |
| 1.3-V regulator                                      | $-5\text{ mA} \leq I_{\text{DIFSENS}} \leq 50\ \mu\text{A}$ | 1.2  | 1.3  | 1.4  |               |
| 0.75-V regulator                                     | REG2 ( $\pm 125\text{ mA}$ )                                | 0.70 | 0.75 | 0.80 |               |
| 1.75-V regulator source current                      | $V_O = 1.25\text{ V}$                                       | -200 |      |      | mA            |
| 1.75-V regulator sink current                        | $V_O = 2.25\text{ V}$                                       | 200  |      |      |               |
| 1.75-V regulator source current limit <sup>(1)</sup> |   | -200 |      | -700 |               |
| 1.75-V regulator sink current limit <sup>(1)</sup>   |   | 200  |      | 700  |               |
| 1.3-V regulator source current                       | $V_{\text{DIFSENS}} = 0\text{ V}$                           | -5   |      | -15  | $\mu\text{A}$ |
| 1.3-V regulator sink current                         | $V_{\text{DIFSENS}} = 2.4\text{ V}$                         | 50   |      | 200  |               |
| 0.75-V regulator source current                      | $V_O = 0.25\text{ V}$                                       | -200 |      |      | mA            |
| 0.75-V regulator sink current                        | $V_O = 1.25\text{ V}$                                       | 200  |      |      |               |
| 0.75-V regulator source current limit <sup>(1)</sup> |   | -200 |      | -700 |               |
| 0.75-V regulator sink current limit <sup>(1)</sup>   |   | 200  |      | 700  |               |

<sup>(1)</sup> Ensured by design. Not production tested.

**TERMINAL FUNCTIONS**

| TERMINAL |           | I/O | DESCRIPTION   |
|----------|-----------|-----|---|
| NAME     | NO.       |     |   |
| HSPGND   | 4         | -   | Heat sink power ground pin.   |
| HSGND    | 5, 12, 13 | -   | Heat sink ground pin which should be attached to the ground plane on a multilayer board or large copper area on a 2 layer board.  |
| REG1     | 6         | O   | 1.75-V source/sink regulated output voltage pin. The part is internally current limited for both sinking and sourcing current to prevent damage. For best performance, a 4.7- $\mu\text{F}$ low-ESR capacitor is recommended. Lead lengths should be kept to a minimum. |
| REG2     | 3         | O   | 0.75-V source/sink regulated output voltage pin. The part is internally current limited for both sinking and sourcing current to prevent damage. For best performance, a 4.7- $\mu\text{F}$ low-ESR capacitor is recommended. Lead lengths should be kept to a minimum. |
| DIFSENS  | 7         | O   | 1.3-V source/sink regulated output voltage pin. The part is internally current limited to the SCSI SPI-2 through SPI-4 standards for both sinking and sourcing current to prevent damage.   |
| TERMPWR  | 2         | I   | Supply voltage pin. The pin should be decoupled with at least a 2.2- $\mu\text{F}$ low-ESR capacitor. For best performance, a 4.7- $\mu\text{F}$ low-ESR capacitor is recommended. Lead lengths should be kept to a minimum.  |

APPLICATION INFORMATION

The resistor stack with the 1.75-V and 0.75-V reference gives the correct differential impedance, bias voltage, common mode differential impedance, and common mode voltage as show in Table 1.

Table 1. UCC561 Resistor Stack vs. Standard (SPI-2 through SPI-4)

| PARAMETER                          | UCC561 | STANDARD   | UNITS    |
|------------------------------------|--------|------------|----------|
| Differential Impedance             | 107.3  | 100 to 110 | $\Omega$ |
| Differential bias voltage          | 112.9  | 100 to 125 | mV       |
| Common-mode differential impedance | 237    | 100 to 300 | $\Omega$ |
| Common-mode voltage                | 1.25   | 1.2 to 1.3 | V        |

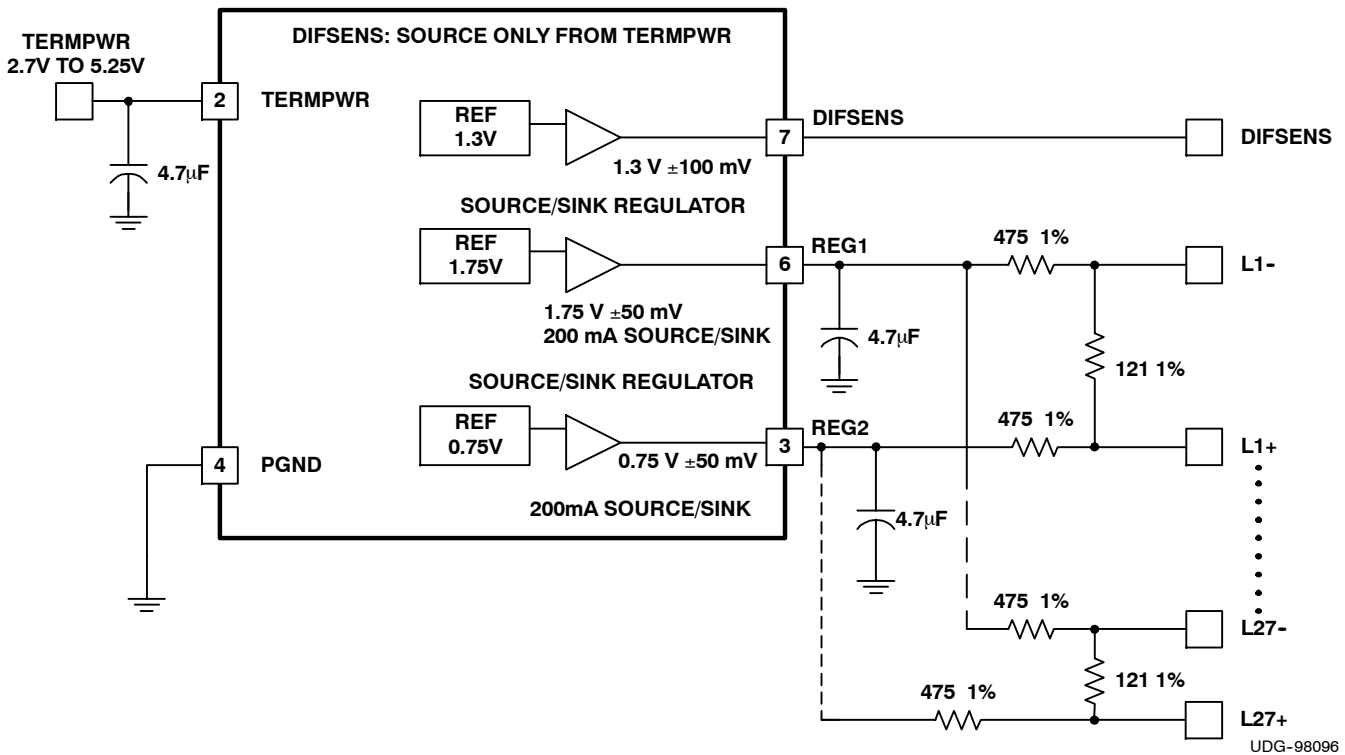

Figure 1. Low-Voltage Differential Discrete Resistor Stack

**PACKAGING INFORMATION**

| Orderable Device | Status <sup>(1)</sup> | Package Type | Package Drawing | Pins | Package Qty | Eco Plan <sup>(2)</sup> | Lead/Ball Finish | MSL Peak Temp <sup>(3)</sup> |
|------------------|-----------------------|--------------|-----------------|------|-------------|-------------------------|------------------|------------------------------|
| UCC561DP         | ACTIVE                | SOIC         | D               | 16   | 40          | Green (RoHS & no Sb/Br) | CU NIPDAU        | Level-1-260C-UNLIM           |
| UCC561DPG4       | ACTIVE                | SOIC         | D               | 16   | 40          | Green (RoHS & no Sb/Br) | CU NIPDAU        | Level-1-260C-UNLIM           |
| UCC561DPTR       | ACTIVE                | SOIC         | D               | 16   | 2500        | Green (RoHS & no Sb/Br) | CU NIPDAU        | Level-1-260C-UNLIM           |
| UCC561DPTRG4     | ACTIVE                | SOIC         | D               | 16   | 2500        | Green (RoHS & no Sb/Br) | CU NIPDAU        | Level-1-260C-UNLIM           |
| UCC561TD         | OBSOLETE              | TO-220       | KC              | 5    |             | TBD                     | Call TI          | Call TI                      |

<sup>(1)</sup> The marketing status values are defined as follows:

**ACTIVE:** Product device recommended for new designs.

**LIFEBUY:** TI has announced that the device will be discontinued, and a lifetime-buy period is in effect.

**NRND:** Not recommended for new designs. Device is in production to support existing customers, but TI does not recommend using this part in a new design.

**PREVIEW:** Device has been announced but is not in production. Samples may or may not be available.

**OBSOLETE:** TI has discontinued the production of the device.

<sup>(2)</sup> Eco Plan - The planned eco-friendly classification: Pb-Free (RoHS), Pb-Free (RoHS Exempt), or Green (RoHS & no Sb/Br) - please check <http://www.ti.com/productcontent> for the latest availability information and additional product content details.

**TBD:** The Pb-Free/Green conversion plan has not been defined.

**Pb-Free (RoHS):** TI's terms "Lead-Free" or "Pb-Free" mean semiconductor products that are compatible with the current RoHS requirements for all 6 substances, including the requirement that lead not exceed 0.1% by weight in homogeneous materials. Where designed to be soldered at high temperatures, TI Pb-Free products are suitable for use in specified lead-free processes.

**Pb-Free (RoHS Exempt):** This component has a RoHS exemption for either 1) lead-based flip-chip solder bumps used between the die and package, or 2) lead-based die adhesive used between the die and leadframe. The component is otherwise considered Pb-Free (RoHS compatible) as defined above.

**Green (RoHS & no Sb/Br):** TI defines "Green" to mean Pb-Free (RoHS compatible), and free of Bromine (Br) and Antimony (Sb) based flame retardants (Br or Sb do not exceed 0.1% by weight in homogeneous material)

<sup>(3)</sup> MSL, Peak Temp. -- The Moisture Sensitivity Level rating according to the JEDEC industry standard classifications, and peak solder temperature.

**Important Information and Disclaimer:**The information provided on this page represents TI's knowledge and belief as of the date that it is provided. TI bases its knowledge and belief on information provided by third parties, and makes no representation or warranty as to the accuracy of such information. Efforts are underway to better integrate information from third parties. TI has taken and continues to take reasonable steps to provide representative and accurate information but may not have conducted destructive testing or chemical analysis on incoming materials and chemicals. TI and TI suppliers consider certain information to be proprietary, and thus CAS numbers and other limited information may not be available for release.

In no event shall TI's liability arising out of such information exceed the total purchase price of the TI part(s) at issue in this document sold by TI to Customer on an annual basis.

**TAPE AND REEL INFORMATION**

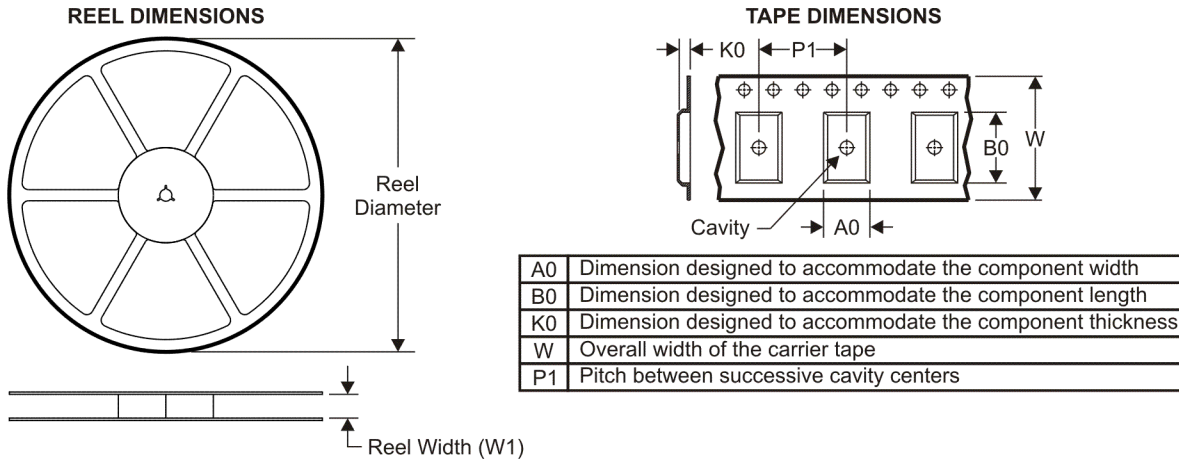

**QUADRANT ASSIGNMENTS FOR PIN 1 ORIENTATION IN TAPE**

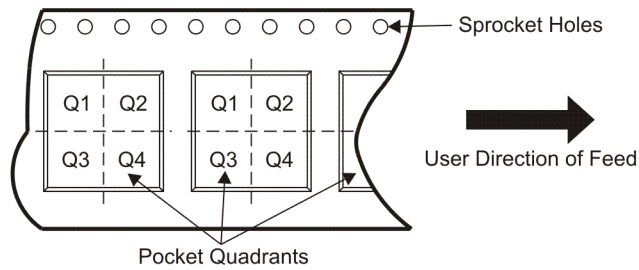

\*All dimensions are nominal

| Device     | Package Type | Package Drawing | Pins | SPQ  | Reel Diameter (mm) | Reel Width W1 (mm) | A0 (mm) | B0 (mm) | K0 (mm) | P1 (mm) | W (mm) | Pin1 Quadrant |
|------------|--------------|-----------------|------|------|--------------------|--------------------|---------|---------|---------|---------|--------|---------------|
| UCC561DPTR | SOIC         | D               | 16   | 2500 | 330.0              | 16.4               | 6.5     | 10.3    | 2.1     | 8.0     | 16.0   | Q1            |

**TAPE AND REEL BOX DIMENSIONS**

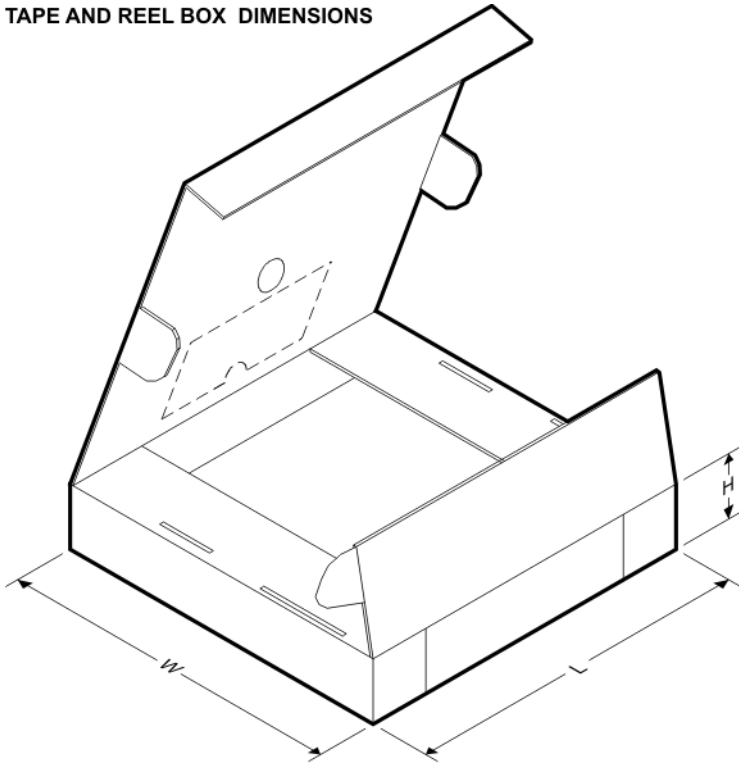

\*All dimensions are nominal

| Device     | Package Type | Package Drawing | Pins | SPQ  | Length (mm) | Width (mm) | Height (mm) |
|------------|--------------|-----------------|------|------|-------------|------------|-------------|
| UCC561DPTR | SOIC         | D               | 16   | 2500 | 333.2       | 345.9      | 28.6        |

D (R-PDSO-G16)

PLASTIC SMALL-OUTLINE PACKAGE

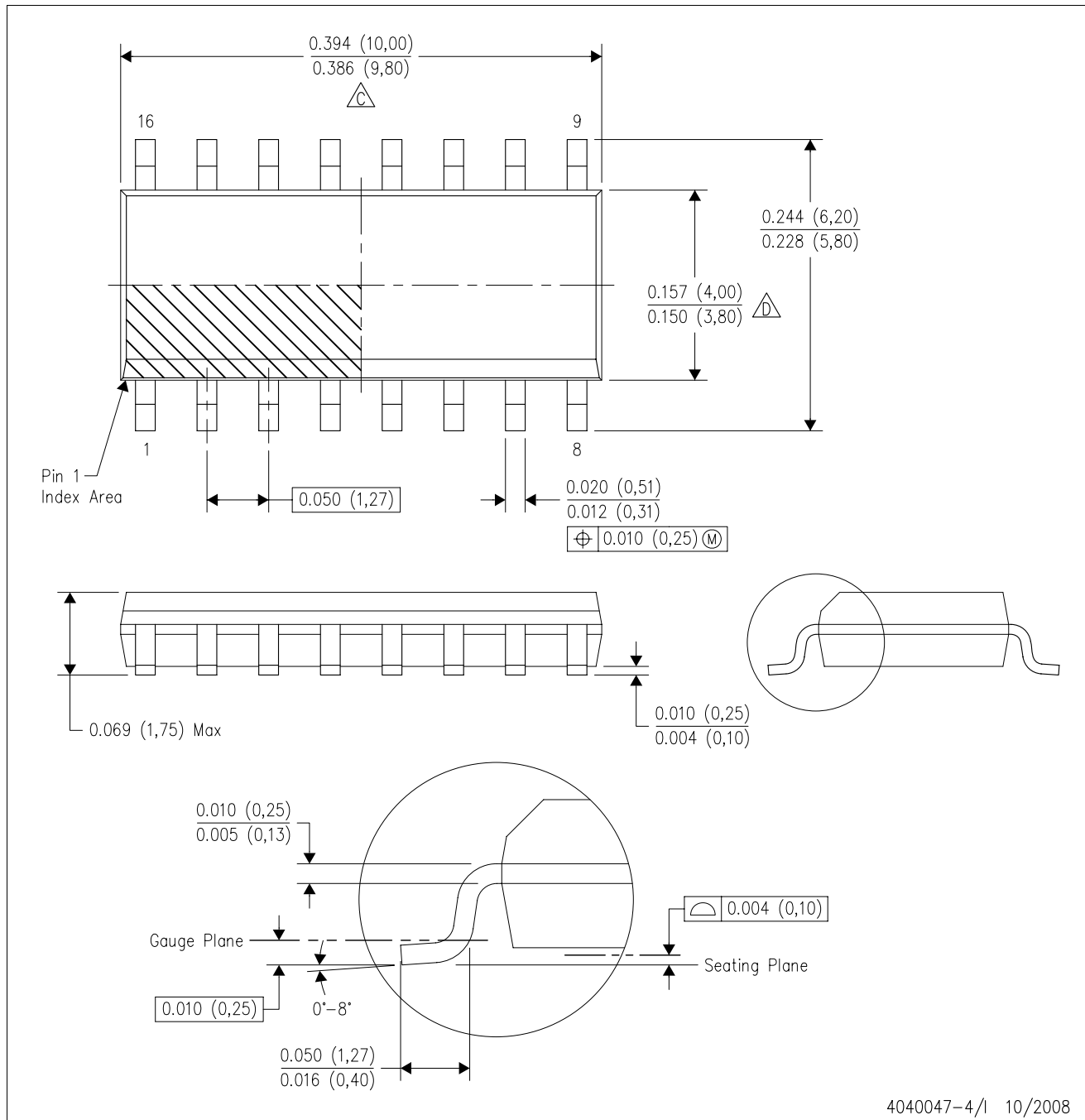



- NOTES:
- A. All linear dimensions are in inches (millimeters).
  - B. This drawing is subject to change without notice.
  - C. Body length does not include mold flash, protrusions, or gate burrs. Mold flash, protrusions, or gate burrs shall not exceed .006 (0,15) per end.
  - D. Body width does not include interlead flash. Interlead flash shall not exceed .017 (0,43) per side.
  - E. Reference JEDEC MS-012 variation AC.

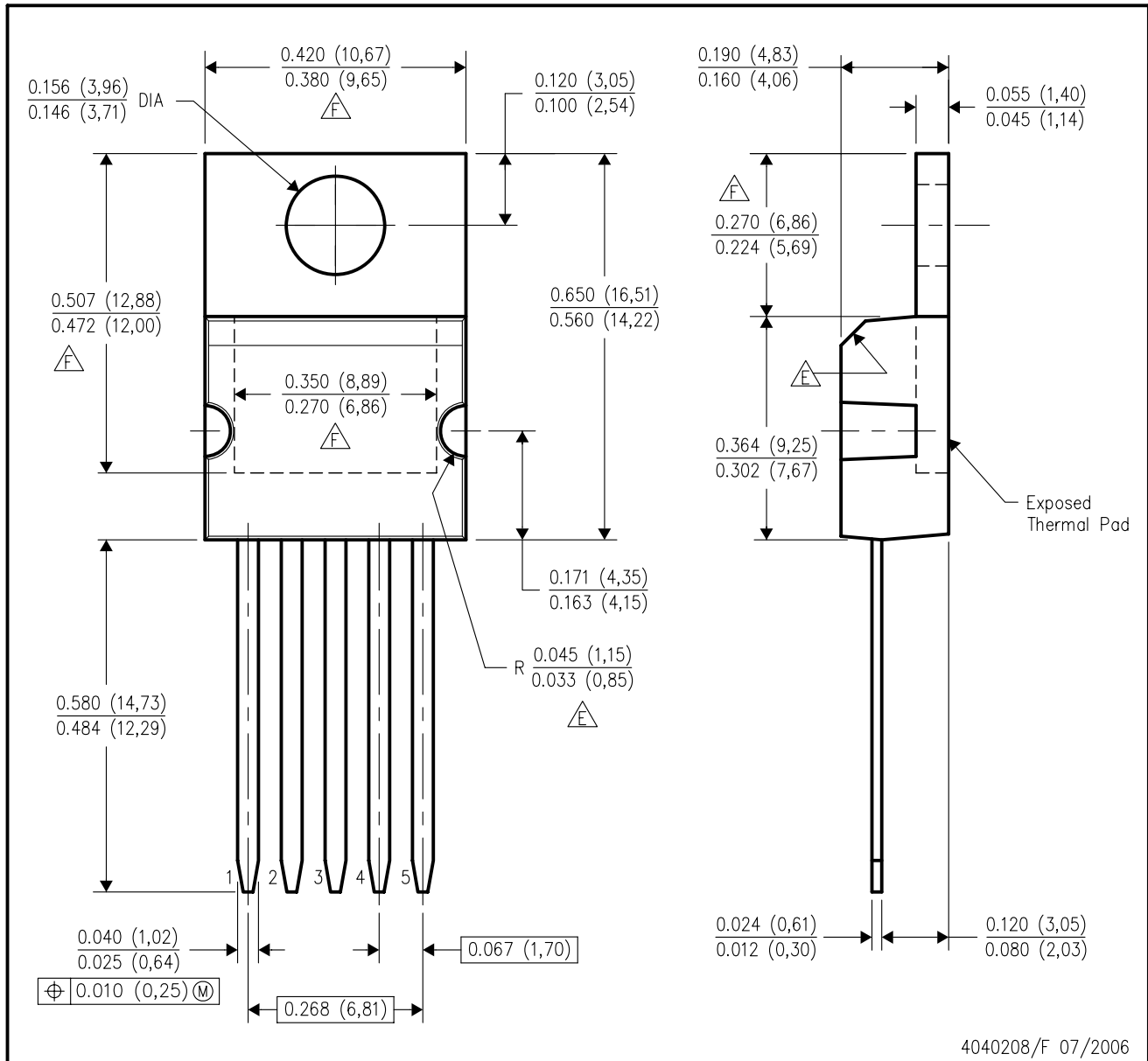

KC (R-PSFM-T5)

PLASTIC FLANGE-MOUNT PACKAGE



- NOTES:
- A. All linear dimensions are in inches (millimeters).
  - B. This drawing is subject to change without notice.
  - C. All lead dimensions apply before solder dip.
  - D. The center lead is in electrical contact with the mounting tab.
  -  These features are optional.
  -  Thermal pad contour optional within these dimensions.

## IMPORTANT NOTICE

Texas Instruments Incorporated and its subsidiaries (TI) reserve the right to make corrections, modifications, enhancements, improvements, and other changes to its products and services at any time and to discontinue any product or service without notice. Customers should obtain the latest relevant information before placing orders and should verify that such information is current and complete. All products are sold subject to TI's terms and conditions of sale supplied at the time of order acknowledgment.

TI warrants performance of its hardware products to the specifications applicable at the time of sale in accordance with TI's standard warranty. Testing and other quality control techniques are used to the extent TI deems necessary to support this warranty. Except where mandated by government requirements, testing of all parameters of each product is not necessarily performed.

TI assumes no liability for applications assistance or customer product design. Customers are responsible for their products and applications using TI components. To minimize the risks associated with customer products and applications, customers should provide adequate design and operating safeguards.

TI does not warrant or represent that any license, either express or implied, is granted under any TI patent right, copyright, mask work right, or other TI intellectual property right relating to any combination, machine, or process in which TI products or services are used. Information published by TI regarding third-party products or services does not constitute a license from TI to use such products or services or a warranty or endorsement thereof. Use of such information may require a license from a third party under the patents or other intellectual property of the third party, or a license from TI under the patents or other intellectual property of TI.

Reproduction of TI information in TI data books or data sheets is permissible only if reproduction is without alteration and is accompanied by all associated warranties, conditions, limitations, and notices. Reproduction of this information with alteration is an unfair and deceptive business practice. TI is not responsible or liable for such altered documentation. Information of third parties may be subject to additional restrictions.

Resale of TI products or services with statements different from or beyond the parameters stated by TI for that product or service voids all express and any implied warranties for the associated TI product or service and is an unfair and deceptive business practice. TI is not responsible or liable for any such statements.

TI products are not authorized for use in safety-critical applications (such as life support) where a failure of the TI product would reasonably be expected to cause severe personal injury or death, unless officers of the parties have executed an agreement specifically governing such use. Buyers represent that they have all necessary expertise in the safety and regulatory ramifications of their applications, and acknowledge and agree that they are solely responsible for all legal, regulatory and safety-related requirements concerning their products and any use of TI products in such safety-critical applications, notwithstanding any applications-related information or support that may be provided by TI. Further, Buyers must fully indemnify TI and its representatives against any damages arising out of the use of TI products in such safety-critical applications.

TI products are neither designed nor intended for use in military/aerospace applications or environments unless the TI products are specifically designated by TI as military-grade or "enhanced plastic." Only products designated by TI as military-grade meet military specifications. Buyers acknowledge and agree that any such use of TI products which TI has not designated as military-grade is solely at the Buyer's risk, and that they are solely responsible for compliance with all legal and regulatory requirements in connection with such use.

TI products are neither designed nor intended for use in automotive applications or environments unless the specific TI products are designated by TI as compliant with ISO/TS 16949 requirements. Buyers acknowledge and agree that, if they use any non-designated products in automotive applications, TI will not be responsible for any failure to meet such requirements.

Following are URLs where you can obtain information on other Texas Instruments products and application solutions:

### Products

|                             |  |
|-----------------------------|--|
| Amplifiers                  | <a href="http://amplifier.ti.com">amplifier.ti.com</a>             |
| Data Converters             | <a href="http://dataconverter.ti.com">dataconverter.ti.com</a>     |
| DSP                         | <a href="http://dsp.ti.com">dsp.ti.com</a>                         |
| Clocks and Timers           | <a href="http://www.ti.com/clocks">www.ti.com/clocks</a>           |
| Interface                   | <a href="http://interface.ti.com">interface.ti.com</a>             |
| Logic                       | <a href="http://logic.ti.com">logic.ti.com</a>                     |
| Power Mgmt                  | <a href="http://power.ti.com">power.ti.com</a>                     |
| Microcontrollers            | <a href="http://microcontroller.ti.com">microcontroller.ti.com</a> |
| RFID                        | <a href="http://www.ti-rfid.com">www.ti-rfid.com</a>               |
| RF/IF and ZigBee® Solutions | <a href="http://www.ti.com/lprf">www.ti.com/lprf</a>               |

### Applications

|                    |  |
|--------------------|--|
| Audio              | <a href="http://www.ti.com/audio">www.ti.com/audio</a>                   |
| Automotive         | <a href="http://www.ti.com/automotive">www.ti.com/automotive</a>         |
| Broadband          | <a href="http://www.ti.com/broadband">www.ti.com/broadband</a>           |
| Digital Control    | <a href="http://www.ti.com/digitalcontrol">www.ti.com/digitalcontrol</a> |
| Medical            | <a href="http://www.ti.com/medical">www.ti.com/medical</a>               |
| Military           | <a href="http://www.ti.com/military">www.ti.com/military</a>             |
| Optical Networking | <a href="http://www.ti.com/opticalnetwork">www.ti.com/opticalnetwork</a> |
| Security           | <a href="http://www.ti.com/security">www.ti.com/security</a>             |
| Telephony          | <a href="http://www.ti.com/telephony">www.ti.com/telephony</a>           |
| Video & Imaging    | <a href="http://www.ti.com/video">www.ti.com/video</a>                   |
| Wireless           | <a href="http://www.ti.com/wireless">www.ti.com/wireless</a>             |

Mailing Address: Texas Instruments, Post Office Box 655303, Dallas, Texas 75265  
Copyright © 2008, Texas Instruments Incorporated